

A —
A —

A-A (1:8)

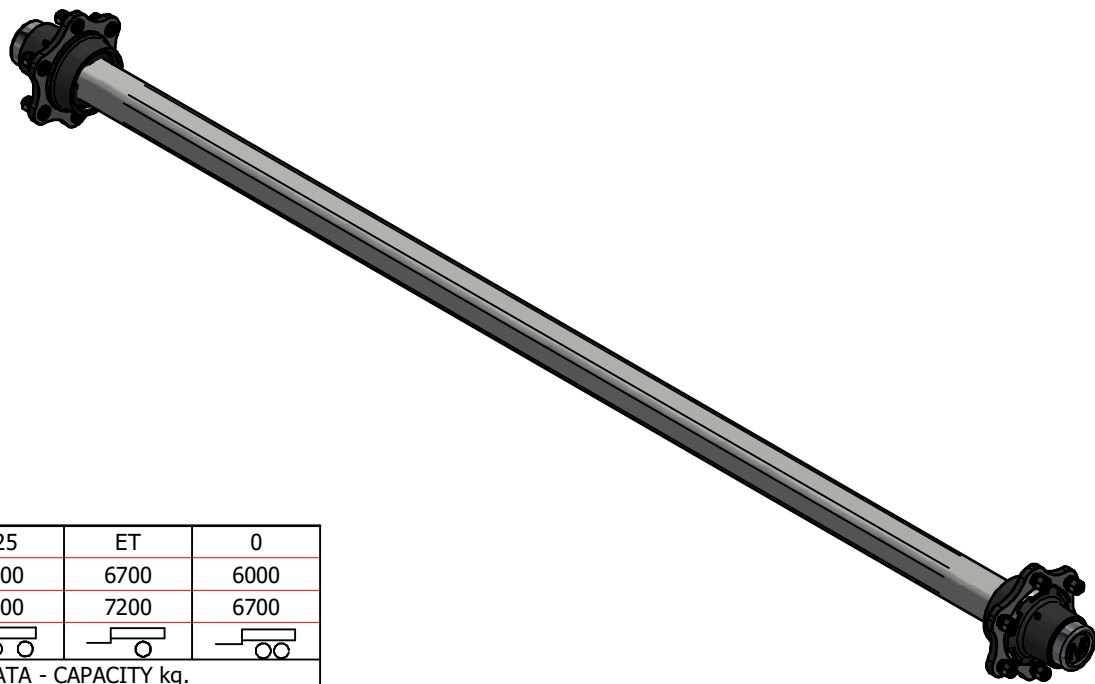
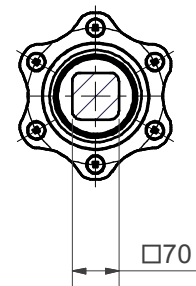

- CON TARGHETTA / WITH DATA PLATE
- CON INGRASSATORE / WITH GREASE NIPPLE

OVERH.	225	ET	0
40	6700	6700	6000
25	7200	7200	6700
km/h			
PORTATA - CAPACITY kg.			

COAT			
LENGHT WITHOUT TOLLERANCE	MATERIAL - HARDNESS		REF. (A3) SCALE 1:8
DIAMETER WITHOUT TOLLERANCE	DRAWN	APPROVED	REPLACE DATE: NAME:
RADIUS WITHOUT DIMENSIONS	DATE 29/07/20	29/07/20	REPLACED BY DATE: NAME:
OWNER V	NAME MAGALINI A.	MERITI R.	
	ASSALE Q070X2550 NA06 160-205 S018 SENZA FRENO GER TAPPO TVZ AXLE S070X2550 NA06 160-205 S018 WITHOUT BRAKE GER TVZ CAP		
DWG. N.*	SHEET	LAST REV.	R.No.
A07006661000106	1/1	29/07/20	0

La ditta si riserva la proprietà di questo disegno. NON DIVULGARE. Confidential copyright reserved NO COPYING OR EXHIBITING.